

ENGLISH
ESPAÑOL



TRUPER®

Manual

Gasoline Engine

6.5 Hp / 9 Hp / 13 Hp

Power

Applies for:

Codes

Models

101327

MOG-65

101328

MOG-90

101329

MOG-130

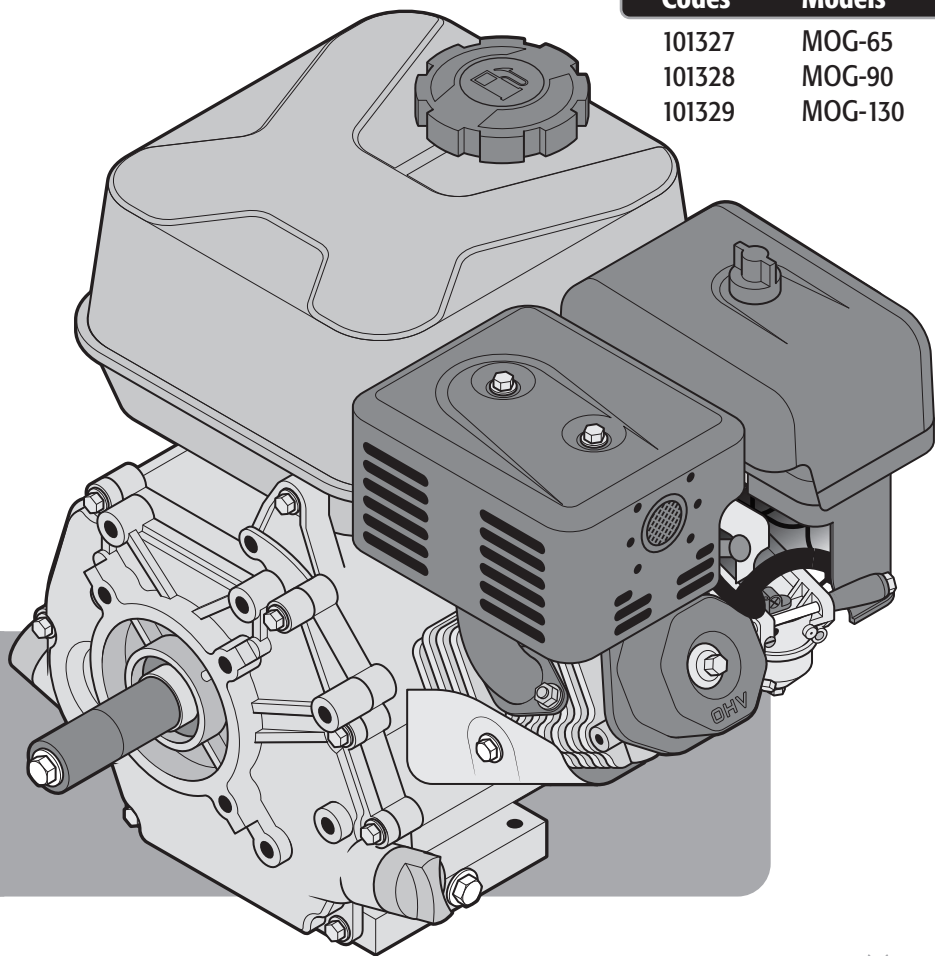

CAUTION





Read this manual thoroughly
before using the tool.



Technical Data **3**

Fuel Specifications **3**

 General Safety Warnings for Motor Tools **4**

 Safety Warnings for Gasoline Engines **5**

Parts **6**

Assembly **7**

Fuel and Oil **8**

Start Up **9**

Maintenance **10**

Troubleshooting **12**

Notes **13**

Authorized Service Centers **15**

Warranty Policy **16**

 **CAUTION**

To gain the best performance of the tool, prolong the duty life, make the Warranty valid if necessary, and to avoid hazards of fatal injuries please read and understand this Manual before using the tool.

Keep this manual for future references.

The illustrations in this manual are for reference only. They might be different from the real tool.

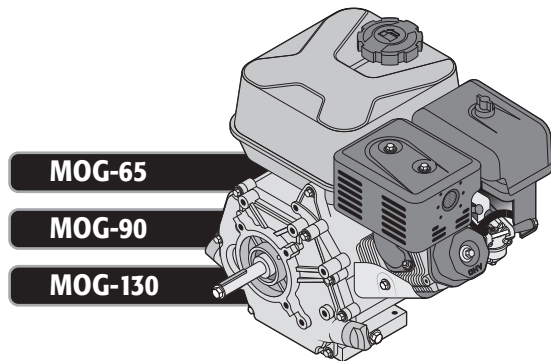

Technical Data



	MOG-65	MOG-90	MOG-130
Code •	101327	101328	101329
Description •	Gasoline Engine		
Motor Cylinders •	212 cm ³	212 cm ³	420 cm ³
Motor Rated Power •	6.5 Hp	9 Hp	13 Hp
Max. Torque •	13.5 N·m	16.4 N·m	26.5 N·m
Motor Type •	4-stroke OHV		
Diameter / Type shaft •	3/4" whit keyseat	1" whit keyseat	
No Load Speed •	3 600 RPM		
Fuel •	Gasoline		
Gas Tank Capacity •	0.95 gal	2.5 gal	1.7 gal
Fuel Consumption •	0.6 l/h	1.0 l/h	1.4 l/h
Oil Type •	SAE 10W/30		
Noise Level •	94 dB		
Weight •	32 lb	53.8 lb	65.5 lb
	Low oil level sensor		

Fuel Specifications

- The equipment has an air-cooled 4-stroke motor using pure unleaded gasoline.
- For no reason at all mix oil with the fuel.

⚠ WARNING • For no reason at all use fuel mixed with ethyl alcohol (gasohol), ethanol or methane. These attract humidity causing separation and acid build up when stored. Acidity can damage the motor fuel system when stored.

- To avoid having problems with the motor, please drain the fuel system before storing the equipment 30 days or longer. Drain the gasoline tank, start the motor and leave it running until the fuel lines are empty. Next season, use fresh gasoline.

- Never use inside the gasoline tank products to clean motors or carburetors. Those products can cause permanent damage to the Motor.

Do not use the equipment in closed areas.

⚠ DANGER Prevent breathing accumulated carbon monoxide, an odorless, toxic and potentially fatal gas.



Never smoke near fuel.

⚠ DANGER Do not smoke near the filling-up area or while operating the equipment.



General Safety Warnings for Motor Tools

Keep your work area clean, tidy and well lit.

CAUTION Cluttered and dark areas may cause accidents.



Never use the tool in explosive areas or in the presence of flammable liquids.

DANGER Before starting the motor keep the tool at least 9 meters (30 feet) away from the fill up area.



Keep children and passersby at a safe distance while operating the tool.

WARNING Distractions could cause losing control and cause accidents.



Avoid contact with power lines and circuits.

DANGER Find and avoid power lines and circuits, especially hidden wiring as well as any grounded object.



Stay alert, use care and common sense.

CAUTION Familiarity with the tool operation could lead to distractions. It could cause accidents.

Refrain from using the tool if tired or under the influence of drugs, alcohol or medication.

DANGER Being momentarily distracted while using the tool could cause severe personal injury.

Operate the tool with guards and protection devices in place and in good working condition.

WARNING Failure to comply with this warning is a hazard of severe personal injury.

Do not force the tool.

CAUTION Working within the tool's working design assures a better and safer job.



Keep the tool in a safe place and out of the reach of children.

WARNING Motor powered tools are dangerous to inexperienced people.



Wear proper clothes.

WARNING Loose clothes, jewelry or long hair could get caught in the mobile parts.



Keep hands away from rotating and/or mobile parts.

WARNING Failure to comply with this warning is a hazard of severe personal injury.



Do not operate the tool in enclosed areas.

DANGER Avoid breathing accumulated carbon monoxide, a potentially deadly odorless toxic gas.



Wear adequate protective safety accessories.

CAUTION Wear eye protection, dust mask, non-skid safety shoes, helmet and ear plugs. These safety gears reduce the risk of injury.



Turn off the tool before adjusting, changing accessories or storin.

WARNING Double check the tool switch is in the off position.

Refrain from operating the tool if the switch is not working or is not properly assembled.

WARNING Failure to comply with this warning is a hazard of personal injury. Immediately send it to a **TRUPER** Authorized Service Center.

Do not overreach.

CAUTION Good balance and support lead to better controlling the tool in unexpected situations.

Avoid the tool to unintentionally start.

WARNING Double-check the tool motor is off before maintenance or putting it away.



Remove brackets before turning on the tool.

DANGER Additional tools or vices installed in a rotating part could cause severe personal injury.

Service the tool and double-check it is in good working conditions before operating.

CAUTION Carefully check mobile parts, alignment and assembly. Do it periodically. Look for any damaged element or part not working properly. Repair immediately in a **TRUPER** Authorized Service Center.



Accessories.

CAUTION Use only accessories or spare parts indicated in this Manual or certified by **TRUPER**.

Never leave a running tool unattended.

DANGER Turn off and disconnect the tool after using. Set it in a safe position to avoid severe injury.

Never smoke in the proximity of fuel.

DANGER Do not smoke in the proximity of the fuelling area or when using the tool.



Do not touch parts with high temperatures.

The surface of the engine and the exhaust reach high temperatures during the operation of the tool.



Service and repair.

Always go to a **TRUPER** Authorized Service Center to use identical spare parts and maintain the security of the tool.

Safety Warnings for Gasoline Engines



Fuel Handling

- Never smoke close to where there is fuel, nor the filling up zone or when operating the pump. 
 - To reduce risk of fire or burns, handle fuel with care. It is extremely flammable. 
 - Prevent gasoline or oil to be in contact with your skin.
 - Protect your eyes to guard off gasoline or oil splashes.
- In the event of accidental contact, wash immediately with clear water. If irritations persist, go see a physician.
- Store fuel in a dedicated container.
- ⚠ WARNING** • Before re-fueling, shut down the motor, set the equipment on clear terrain and wait for it to cool down.
- ⚠ CAUTION** • Wipe clean all the spilled fuel before operating the equipment.
- ⚠ CAUTION** • Check for fuel leaks to prevent fire, or burns. If there are leaks, mend them before using the pump.
- Under no reason at all burn spilled fuel to get rid of it.
 - Por ningún motivo utilice cualquier otro tipo de combustible que el especificado en el instructivo.

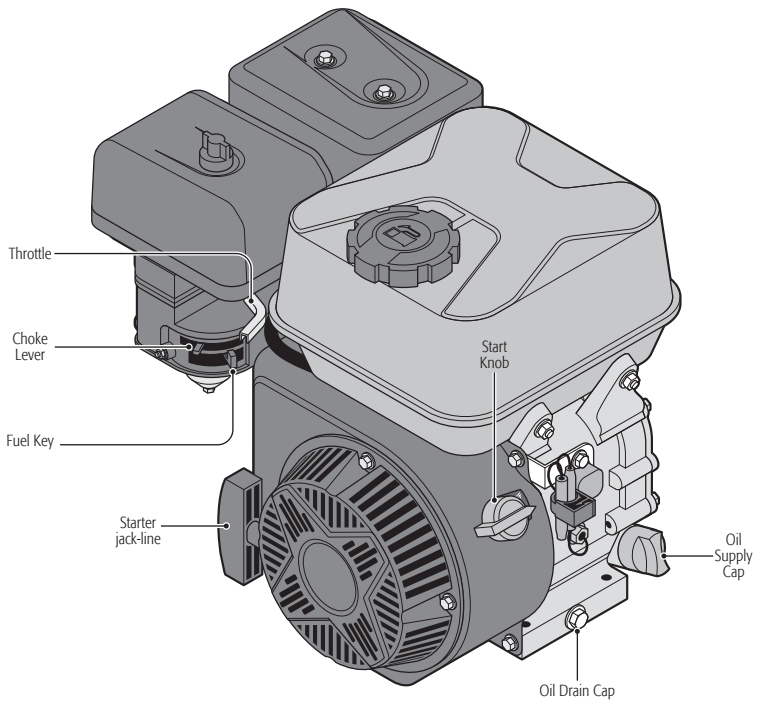
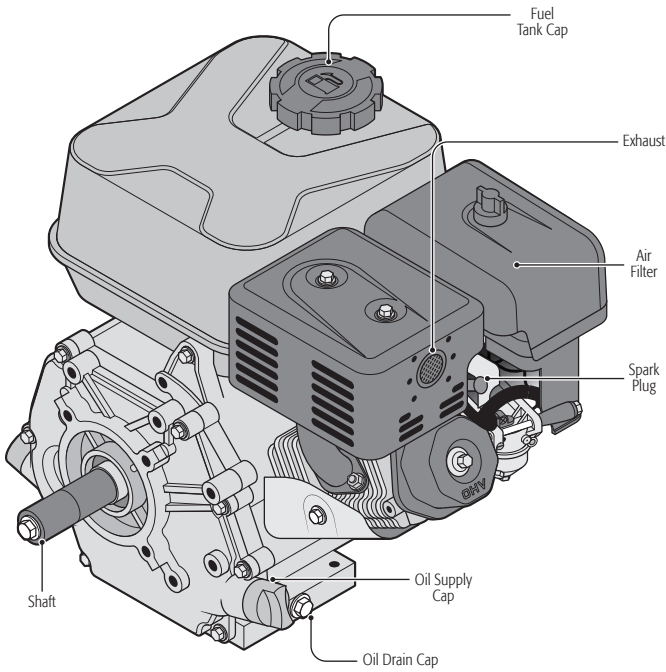

Engine mount

- The motor must be attached to a plate (A) welded to the structure or chassis of the machine where the engine will be housed. This plate must be larger than the base of the engine and have four perforations to fix the motor with four sets of hexagonal bolts.

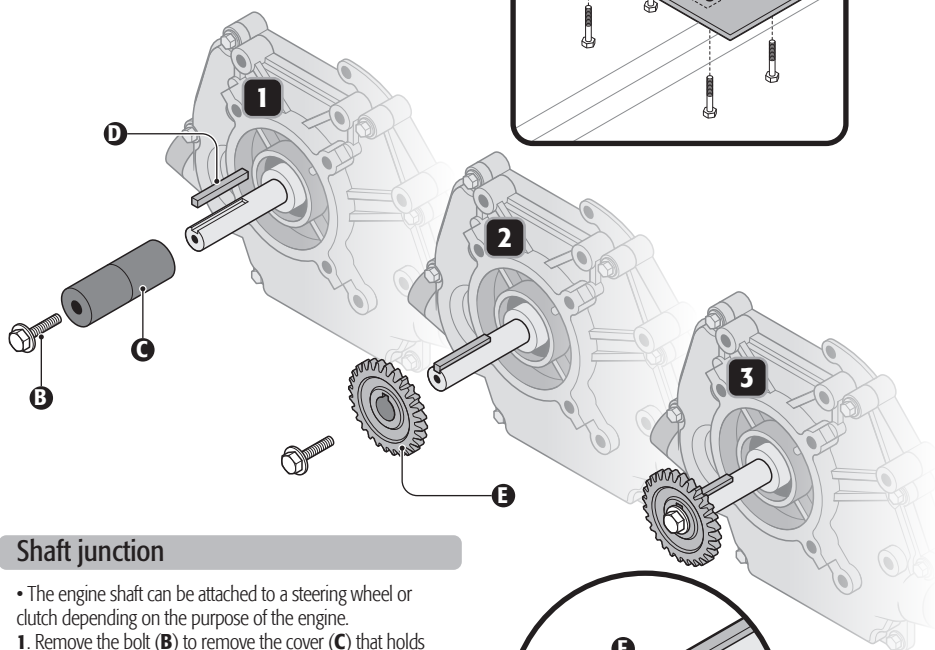
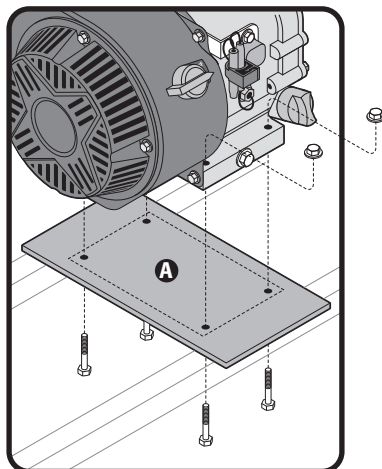

Shaft junction

- The engine shaft can be attached to a steering wheel or clutch depending on the purpose of the engine.

- Remove the bolt (B) to remove the cover (C) that holds the wedge (D) in place.
- Place the steering wheel (E) or clutch on the motor shaft not without first placing the key on the shaft to match the steering wheel slot (F).
- Secure the steering wheel on the shaft with the bolt (B).

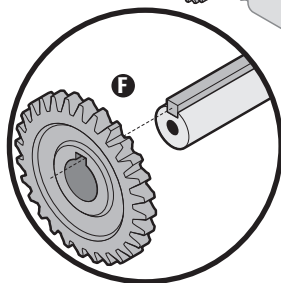

Oil Supply (A)

- Set the equipment onto a flat and leveled surface.
- Turn and remove the oil supply cap.
- Use 4-stroke motor oil. Using SAE 10W/30 general oil for all temperatures is recommended. As indicated in the following table, other viscosities can be used when the local average temperature is within the indicated range.

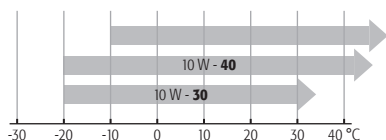

- Set back the cap and remove it to check oil level in the cap oil measuring rod.
- Once the oil tank is in the right level indicated in the rod, tighten the cap to prevent leaks.

⚠ CAUTION • Do not exceed the oil maximum level because it causes a lot of smoke when starting the motor.

⚠ CAUTION • Check the oil level before each use. If necessary, add oil until the level is between the limits in the cap rod.

⚠ CAUTION • Replace oil after 20 hours' operation or each season. It may be necessary to replace oil more often during dusty or dirt conditions.

High Altitude Operation

• In high altitudes, the air-fuel combination in a standard carburetor will be rich in fuel. Performance will be low and fuel consumption will increase.

• Performance while operating in high altitudes may improve if the carburetor is regulated adjusting the main knob. The machine is adjusted to operate at altitudes above 6000 feet over sea level. If noticing the machine is not operating efficiently go to a **TRUPER** Authorized Service Center to carry out the modification needed in the carburetor.

• Even though the carburetor is having an adequate injection, the motor power will diminish approximately 3.5% per each increase of 1000 feet after 6890 feet above sea level. The power decrease will be higher if no modifications are carried out in the carburetor.

⚠ WARNING • If the machine is operated in a height inadequate to the carburetor adjustment, low performance, overheating and severe damage in the motor can be caused due to the excessive air mix in the fuel.

Fuel Supply (B)

- Set the Pressure Washer on a flat and leveled surface.
- Clean and dry the area around the fuel cap.
- Remove the fuel cap.
- Using a funnel fill slowly the fuel tank up to the lower part of the tank neck. Do not overfill to allow fuel expansion and prevent spillage.
- Clean any fuel spills.
- Cover the tank rotating the cap until hearing a click.
- Clean any spilled fuel before starting up.

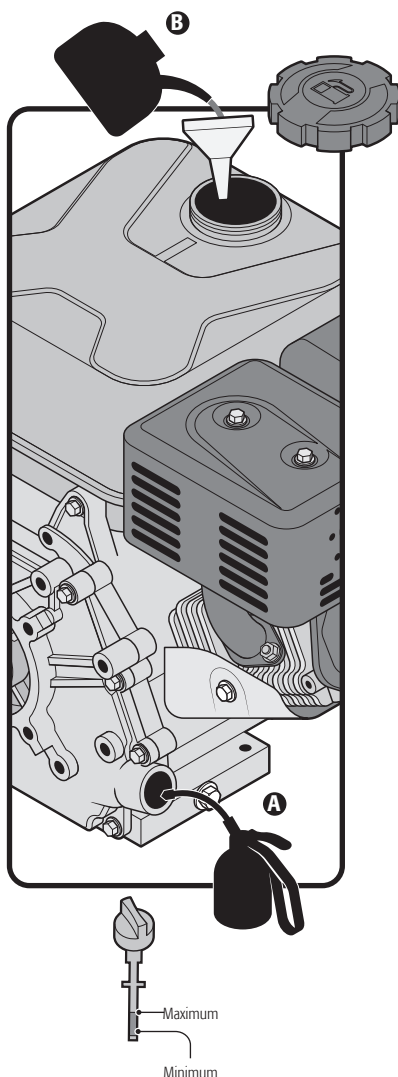

Start Up

⚠ CAUTION Before starting the pump some topics need to be taken care of. Otherwise it can get damaged and the Warranty cancelled:

- All the hoses shall be disconnected, totally untangled and with no kinks.
- Water supply shall be connected and fully open.
- Gasoline and oil levels shall be right.
- The system shall be purged as previously indicated.

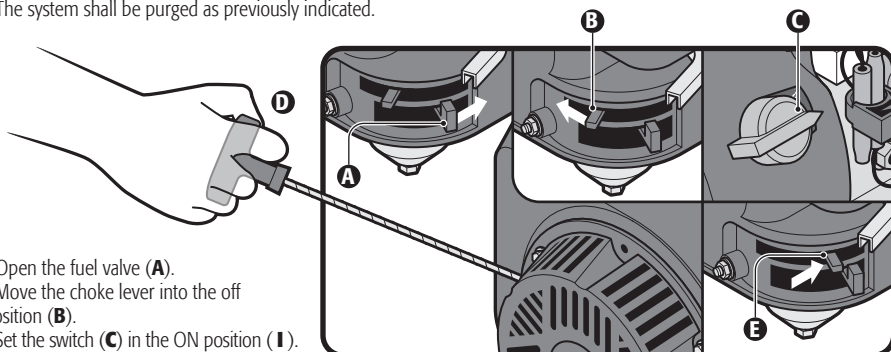

- Open the fuel valve (A).
- Move the choke lever into the off position (B).
- Set the switch (C) in the ON position (I).
- Move the throttle lever (G) to the high-speed position (II).
- Slowly pull the starter lever (D) until filling resistance in the line. Then, pull with force to start the motor. **⚠ CAUTION** Carefully return the lever to its place. do not release it, otherwise it would snap back and get damaged.
- Allow the motor to run 5 seconds, and then move the choke lever into the "ON" position (E).

⚠ CAUTION • Keep on paying CAUTION to the water source level because during the pumping operation the level could go so low until the suction hose end is out of the water. In this situation turn off the pump immediately and correct the suction hose depth. Avoid making the pump function with no water, otherwise it may get damaged.

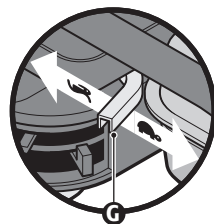

Shut OFF

- Move the throttle lever (G) into the low speed position (I).
- Turn off the switch (C).
- Move the fuel lever (A) moving the lever into the closed (OFF) position.
- Move the choke lever (D) into the "OFF" position.

⚠ CAUTION • To stop the motor during an emergency, set the motor switch directly into the "OFF" position.

⚠ CAUTION • Regular and careful maintenance is essential to maintain the safety levels and the optimal performance of the equipment.

- Before cleaning, repairing, inspecting or storing the equipment, shut off the motor and wait until the motor is completely cooled down.
- Keep nuts, bolts and screws tight to assure the equipment is in a safe working condition.
- Do not alter the safety devices. Verify regularly if they work right.

- Any worn or damaged part shall be replaced before using the equipment. Do not try to repair the parts. It can damage the equipment and become a risk to your safety.
- Any repair or maintenance works different to those described in this section, for example, adjusting the carburetor, shall be carried out only in a Authorized Service Center.

Regular Maintenance	Before Each Use	Every 20 h or each month	Every 50 h or 3 months	Every 100 h or 6 months	Every 300 h or every year
General Inspection	Carry Out				
Motor Oil	Check	Change		Change	
Air Filter	Check		Clean (1)		
Sediment Container				Clean	
Spark Plug				Clean / Readjust	
Valve Clearance					Clean / Readjust (2)
Fuel Tank and Sieve					Clean (2)
Fuel Line		Check and replace every 3 years if necessary (2)			
Fuel Tank Cap				Clean	
Fuel Filter					Clean

1. When operating the equipment in dusty places carry out maintenance more frequently.
2. Go to a Authorized Service Center for this service.

Air Filter

- Check the air filter to ensure is in good conditions. Remember, a dirty filter can make starting difficult, loosing performance and shorten the working life of the motor.
- Remove the wing nut, then remove the filter cover and the filter element.
- Set apart both the sponge filter from the paper filter elements.
- Wash the sponge filter with a detergent and hot water solution. Let the filter dry completely.
- Soak the sponge filter in clean SAE-20 motor oil. Squeeze out until eliminating excessive oil. The motor may expel smoke during start up if too much oil is left.
- Install back the filter in its container and set the cover back in place.

⚠ CAUTION Never use gasoline to clean the air filter. It could cause and explosion or fire. Never start the motor with the air filter removed. The motor will wear out faster.

Oil Replacement

- The oil drain cap is under the motor (**B**).
- Set the dedicated container underneath the motor to receive the oil. Remove the drain cap and then, the tank cap (**C**). When the oil has drained, set back the drain cap.
- Wipe clean any leak or spill.
- Fill up the tank with SAE-10W/30 oil.
- Check oil level placing the oil tank cap without screwing it back. Oil level shall be between the *maximum* and *minimum* marks in the oil measuring rod. Double check the level is not exceeding the *maximum* mark. When the level is right, tighten the tank cap.
- Start the motor. Leave it running a few moments. Stop the motor, wait one minute and check again oil level. Fill up if necessary.
- For no reason at all, pour oil in the drain. Take used oil and oil filter to a recycling unit.

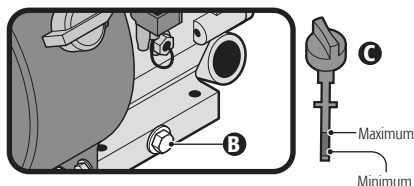

Fuel Filter

- The fuel filter stops water or dirt present in the fuel tank to enter into the carburetor.
- If the motor has not been run after a long period of time, the sediment container need cleansing.
- With the motor off and ambient temperature close the fuel key (E).
- Remove the sediment container (F). Clean its interior.
- Leave the container drying completely.
- Verify the washer (G) is in good conditions and set the sediment container back in place.
- The tank fuel filter shall be washed according to the maintenance program indicated in page 11.

NOTE These instructions apply only for models MOTB-2 and MOTB-3

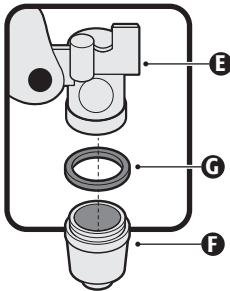

Spark Plug

- Before removing the spark plug (B), wipe clean the area around the spark plug base to stop dust and debris entering the motor. Then, using a spark-plug wrench remove the spark plug.
- Clean the carbon deposits from the spark plug electrodes using a spark plug cleaner or a wire brush.
- Replace the old spark plug with a new one if damaged, worn or if in doubt.
- Measure the gap between both electrodes. Use a spark plug gauge. The distance between the center electrode and the side electrode shall be between 0.27" and 0.31"
- Check the spark plug washer is in good conditions. Insert the spark plug manually to prevent maladjustment.
- After setting the spark plug, tighten with a spark plug wrench to compress the washer.

CAUTION If installing a new spark plug, tighten half-a-turn until the spark plug is in place and can press the washer. If installing a used spark-plug, tighten 1/8 of a turn after the spark plug is in place and can press the washer.

WARNING Improperly installed or out of range spark plugs cause overheating and damage the motor.

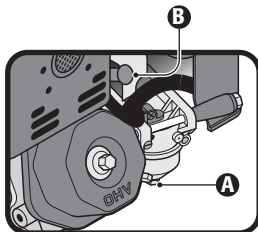

Fuel Drain

- Set a dedicated container under the tank to receive gasoline. Use a funnel to prevent fuel spills.
- Close the fuel key. Remove and clean the fuel filter as indicated above.
- Before setting the filter, open the filter key to drain all the fuel tank contents. When drained, place the filter and the sediment container.
- Set a dedicated container under the carburetor to receive gasoline. Use a funnel to prevent fuel spills.
- Remove the drain bolt (A).
- When fuel has been drained into the container, set the drain bolt back and the washer. Tighten firmly.
- Wipe clean all the fuel spills.



Storing and Transportation

- When moving the equipment, shut down the motor switch and close the fuel key. Keep the equipment leveled to prevent fuel spills.
- When storing the equipment long periods of time:
 - Drain completely all the fuel as indicated in the previous paragraph. Then, start the motor until all the fuel inside the motor is consumed.
 - Replace oil as indicated in page 11.
 - Remove the spark plug and pour a spoonful of SAE-10W/30 oil into the cylinder. Pull the jack-line to distribute the oil through the system. Set the spark plug back in place.
 - Pull softly the jack-line handle until feeling resistance. This indicated the cylinder is reaching the compression phase and the escape and absorption valves are closed. Storing the equipment in these conditions prevents internal corrosion.
 - Wipe clean the equipment with a damp cloth and cover it to prevent dust accumulation.
 - Store the equipment in a clean, dry place, away from the reach of children.

Problem	Cause	Solution
Motor does not start.	<ul style="list-style-type: none">• The switch is OFF.• Not enough fuel.• Oil level is too low or there is no oil.• Gasoline is not getting into the carburetor.• No spark in the spark plug.	<ul style="list-style-type: none">• Turn ON the switch.• Fill up fuel tank.• Check oil level as indicated in page 8.• Having the fuel tank full, verify fuel flow in the carburetor:<ol style="list-style-type: none">1. Set a dedicated container under the carburetor and use a funnel to prevent fuel spills.2. Remove the drain bolt. Fuel shall flow freely. Otherwise, go to a  TRUPER Authorized Service Center.• Verify the spark plug spark:<ol style="list-style-type: none">1. Disconnect the spark plug cable, wipe clean dust around the spark plug and remove it.2. Connect the cable to the spark plug.3. Turn on the motor.4. Make the spark plug electrode contact any metal part in the motor that is free of fuel. <p>⚠ CAUTION Is important to carry out tests in a ventilated area with no fuel spilled, otherwise an explosion may occur.</p> <ol style="list-style-type: none">5. Pull the jack-line handle to generate a spark between the spark plug central electrode and the metal part. If there is no spark, the spark plug needs replacement.6. If with a new spark plug still is no spark go to a  TRUPER Authorized Service Center.
The motor starts but stops unexpectedly.	<ul style="list-style-type: none">• Oil level is too low.	<ul style="list-style-type: none">• Check motor level as indicated on page 8. Start the motor again.

If problems persist despite all the corrective actions contact a  **TRUPER** Authorized Service Center.

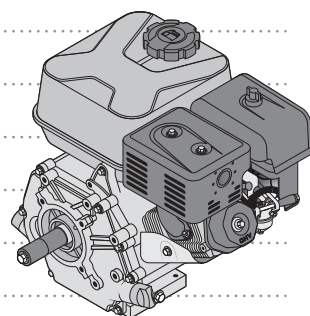

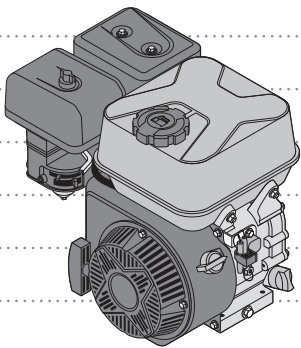

In the event of any problem contacting a  **TRUPER** Authorized Service Center, please see our webpage www.truper.com to get an updated list, or call our toll-free numbers **800 690-6990** or **800 0187-8737** to get information about the nearest Service Center.

- AGUASCALIENTES** **DE TODO PARA LA CONSTRUCCIÓN**
GRAL. BARRAÇAN #1201, COL. GREMIAL, C.P. 20030,
AGUASCALIENTES, AGS. TEL.: 449 994 0537
- BAJA CALIFORNIA** **SUCURSAL TIJUANA**
AV. LA ENCHANTADA, LOTE #5, PARQUE INDUSTRIAL EL
FLORIDO II, C.P. 22244, TIJUANA, B.C.
TEL.: 664 969 5100
- BAJA CALIFORNIA SUR** **FIX FERRETERÍAS**
FELIPE ANGELES ESQ. RUIZ CORTÍNEZ S/N, COL. PUEBLO
NUEVO, C.P. 23670, CD. CONSTITUCIÓN, B.C.S.
TEL.: 613 152 1115
- CAMPECHE** **TORNILLERÍA Y FERRETERÍA AAA**
AV. ÁLVARO OBREGÓN #324, COL. ESPERANZA
C.P. 24080 CAMPECHE, CAMP. TEL.: 981 815 2808
- CHIAPAS** **FIX FERRETERÍAS**
AV. CENTRAL SUR #27, COL. CENTRO, C.P. 30700,
TAPACHULA, CHIS. TEL.: 962 118 4083
- CHIHUAHUA** **SUCURSAL CHIHUAHUA**
AV. SILVESTRE TERRAZAS #128-11, PARQUE INDUSTRIAL
BAFAR, CARRETERA MEXICO CUAUHTÉMOC, C.P. 31415,
CHIHUAHUA, CHIH. TEL. 614 434 0052
- MEXICO CITY** **FIX FERRETERÍAS**
EL MONSTRUO DE CORREGIDORA, CORREGIDORA # 22,
COL. CENTRO, C.P. 06060, CUAUHTÉMOC, CDMX.
TEL.: 55 5522 5051 / 5522 4861
- COAHUILA** **SUCURSAL TORREÓN**
CALLE METAL MECÁNICA #280, PARQUE INDUSTRIAL
ORIENTE, C.P. 27278, TORREÓN, COAH.
TEL.: 871 209 68 23
- COLIMA** **BOMBAS Y MOTORES BYMTESA DE MANZANILLO**
BLVD. MIGUEL DE LA MADRID #190, COL. 16 DE
SEPTIEMBRE, C.P. 28259, MANZANILLO, COL.
TEL.: 314 332 1986 / 332 8013
- DURANGO** **TORNILLOS ÁGUILA, S.A. DE C.V.**
MAZURIO #200, COL. LUIS ECHEVERRÍA, DURANGO,
DGO. TEL.: 618 817 1946 / 618 818 2844
- ESTADO DE MEXICO** **SUCURSAL CENTRO JILOTEPEC**
AV. PARQUE INDUSTRIAL #1-A, C.P. 54240, JILOTEPEC,
EDO. DE MÉX. TEL: 761 782 9101 EXT. 5728 Y 5102
- GUANAJUATO** **ÍA. FERRETERA NUEVO MUNDO S.A. DE C.V.**
AV. MEXICO - JAPÓN #225, CD. INDUSTRIAL, C.P. 38010,
CELAYA, GTO. TEL.: 461 617 7578 / 79 / 80 / 88
- GUERRERO** **CENTRO DE SERVICIO ECLIPSE**
CALLE PRINCIPAL MZ1 LT 1, COL. SANTA FE, C.P. 39010,
CHILPANCIINGO, GRO. TEL.: 747 478 5793
- HIDALGO** **FERREPRECIOS S.A. DE C.V.**
LIBERTAD ORIENTE #304 LOCAL 30, INTERIOR DE PASAJE
ROBLEDO, COL. CENTRO, C.P. 43600, TULANCINGO,
HGO. TEL.: 775 753 6615 / 775 753 6616
- JALISCO** **SUCURSAL GUADALAJARA**
AV. ADOLFO B. HORN # 6800, COL: SANTA CRUZ DEL
VALLE, CP: 45655, TLAJOMULCO DE ZÚNIGA, JAL.
TEL.: 33 3606 5285 AL 90
- MICHOACÁN** **FIX FERRETERÍAS**
AV. PASEO DE LA REPÚBLICA #3140-A, COL.
EX-HACIENDA DE LA HUERTA, C.P. 58050, MORELIA,
MICH. TEL.: 443 334 6858
- MORELOS** **FIX FERRETERÍAS**
CAPITAN ANZÚRES #95, ESQ. JOSÉ PERDIZ, COL.
CENTRO, C.P. 62740, CUAUTLA, MOR.
TEL.: 735 352 8931
- NAYARIT** **HERRAMIENTAS DE TEPEC**
MAZATLAN #117, COL. CENTRO, C.P. 63000, TEPEC, NAY.
TEL.: 311 258 0540
- NUEVO LEÓN** **SUCURSAL MONTERREY**
CARRETERA LAREDO #300, 18 MONTERREY PARKS,
COLONIA PUERTA DE ANAHUAC, C.P. 66052, ESCOBEDO,
NUEVO LEÓN, TEL.: 81 8352 8791 / 81 8352 8790
- OAXACA** **FIX FERRETERÍAS**
AV. 20 DE NOVIEMBRE #910, COL. CENTRO, C.P. 68300,
TUXTEPEC, OAX. TEL.: 287 106 3092
- PUEBLA** **SUCURSAL PUEBLA**
AV. PERIFÉRICO #2-A, SAN LORENZO ALMECATLA,
C.P. 72710, CUAUTLACINGO, PUE.
TEL.: 222 282 8282 / 84 / 85 / 86
- QUERÉTARO** **ARU HERRAMIENTAS S.A DE C.V.**
AV. PUERTO DE VERACRUZ #110, COL. RANCHO DE
ENMEDIO, C.P. 76842, SAN JUAN DEL RÍO, QRO.
TEL.: 427 268 4544
- QUINTANA ROO** **FIX FERRETERÍAS**
CARRETERA FEDERAL MZ. 46 LT. 3 LOCAL 2, COL. EJIDAL,
C.P. 77710 PLAYA DEL CARMEN, Q.R.
TEL.: 984 267 3140
- SAN LUIS POTOSÍ** **FIX FERRETERÍAS**
AV. UNIVERSIDAD #1850, COL. EL PASEO, C.P. 78320,
SAN LUIS POTOSÍ, S.L.P. TEL.: 444 822 4341
- SINALOA** **SUCURSAL CULIACÁN**
AV. JESÚS KUMATE SUR #4301, COL. HACIENDA DE LA
MORA, C.P. 80143, CULIACÁN, SIN.
TEL.: 667 173 9139 / 173 8400
- SONORA** **FIX FERRETERÍAS**
CALLE 5 DE FEBRERO #517, SUR LT. 25 MZ. 10, COL.
CENTRO, C.P. 85000, CD. OBREGÓN, SON.
TEL.: 644 413 2392
- TABASCO** **SUCURSAL VILLAHERMOSA**
CALLE HELIO LOTES 1, 2 Y 3 MZ. #1, COL. INDUSTRIAL,
2A ETAPA, C.P. 86010, VILLAHERMOSA, TAB.
TEL.: 993 353 7244
- TAMAULIPAS** **VM ORINGS Y REFACCIONES**
CALLE ROSITA #527 ENTRE 20 DE NOVIEMBRE Y GRAL.
RODRÍGUEZ, FRACC. REYNOSA, C.P. 88780, REYNOSA,
TAMS. TEL.: 899 926 7552
- TLAXCALA** **SERVICIOS Y HERRAMIENTAS INDUSTRIALES**
PABLO SIDAR #132, COL. BARRIO DE SAN BARTOLOMÉ,
C.P. 90970, SAN PABLO DEL MONTE, TLAX.
TEL.: 222 271 7502
- VERACRUZ** **LA CASA DISTRIBUIDORA TRUPER**
BLVD. PRIMAVERA ESQ. HORTENSIA S/N, COL.
PRIMAVERA, C.P. 93308, POZA RICA, VER.
TEL.: 782 823 8100 / 826 8484
- YUCATÁN** **SUCURSAL MÉRIDA**
CALLE 33 #600 Y 602, LOCALIDAD ITZINCAB Y Mulsay,
MPIO. UMANÁ, C.P. 97390, MÉRIDA, YUC.
TEL.: 999 912 2451

Codes	Models	Brand
101327	MOG-65	 TRUPER®
101328	MOG-90	
101329	MOG-130	

This product is guaranteed for 1 year. To make the warranty valid or purchase parts and components you must present the product in Corregidora 22, Col. Centro, Alc. Cuauhtémoc, CDMX C.P. 06060 or at the establishment where you purchased it, or at any Truper® Service Center listed in the annex to the warranty policy and/or in www.truper.com. Transportation costs resulting from compliance of this warranty will be covered by  **TRUPER®**

For questions or comments, call **800-690-6990**. Made in China. Imported by Truper S.A. de C.V. Parque Industrial 1, Jilotepec, Edo. de Méx. C.P. 54240

Stamp of the business. Purchase date:



**1
YEAR**